

Tank management

SCANRAD SC R8

Introduction

The Scanjet SCANRAD SC R8 is a robust and reliable radar for measurement of level/ullage in tanks, built for harsh marine environments and industrial applications. The SC R8 is a high-performance instrument that accurately tracks the liquid level in the tank throughout operations.

Application

The SC R8 is a radar for level measurement for all types of liquids. This makes it suitable for marine tanks and land tanks containing for example:

- Unrefined hydrocarbons, such as Crude Oil and Condensate.
- Refined hydrocarbons, such as Diesel, Gasoline, Jet Fuel, Bitumen and Lubricants.
- A very wide range of Chemicals from IMO ship type 1 to 3.
- Water and water-based substances as well as Alcohols.

The SC R8 has a high dynamic range and can measure effectively on liquids with dielectric constants of 1.6. This makes the radar well-suited for Crude Oil Tankers, Product Tankers and Chemical Tankers as well as Bitumen Tankers and Shuttle Tankers for ships transporting liquids. It is also good for marine fuel tank measurement.

The SC R8 is used on land installations on storage tanks and process tanks in many industries, from chemical industries to fuel depots.

Working principle

The SC R8 is a non-contacting radar level transmitter. It operates on the 80 GHz band, with a half power beam width of 3°. The device is intrinsically safe for use in a Hazardous area. It is a 2-wire device with 4-20 mA HART protocol. The software can be setup to filter away echoes from obstacles and disturbances to make accurate readings, and thanks to its high band width the radar can track the liquid very close to the tank bottom and roof.

Benefits

The antenna and wetted parts of the SC R8 are designed to minimize any risk of deposits of condensation or residues. The drip-off design and the smooth surface, together with



a radar with high dynamic range means no cleaning, and as there are no hidden surfaces or pockets it is the ideal choice for chemicals.

The radar handles foam, turbulence, or waves on the liquid surface. With the 80 GHz radar signal, measurements are done near the tank bottom and tank roof without problems.

With the low weight and narrow beam, it is easy to install onboard, and the 2-wire interface reduces cabling costs. It is also fully integrated with the SURVEYOR cargo monitoring system.

Accessories

An integrated service display can be installed in the radar unit, for diagnostics and changes of configuration in the radar.

It is possible to co-locate vapor pressure sensors on the same deck socket as the radar and to run cabling via the radar using a 4-wire cable to keep down cost.



Performance data

Radar measurement

Measuring range:	0–35 m
Instrument accuracy :	±2 mm
Beam angle (Half Power Beam Width):	3° Lobe
Radar center frequency:	80 GHz, FMCW
Measuring interval:	< 1 s

Environmental conditions

Ambient temperature:	-40 °C to +80 °C
Storage and transportation:	-40 °C to +100 °C, < 95% RH
Process temperature:	-40 °C to +150 °C
Tank pressure:	Max 4 MPa (40 bar)

Technical data

Electrical

Output signal:	4-20mA / HART
Power supply:	21.6–26.4 VDC

Mechanical

Weight:	7 kg
Material:	SS 316L (Mo 2.8)
Wetted material:	SS 316L (Mo 2.8), PTFE
Cable conduits:	1 x M20 x 1.5 1 x M25 x 1.5
Deck flange:	DN80 PN40

Approvals / Certification

Explosion protection (Intrinsically Safe):	⊕ II 1G Ex ia IIC T6..T2 Ga ⊕ II 1D Ex ia IIIC T85°C...T300°C Da TÜV 20 ATEX 8583X IECEX TUR 20.0053X
Marine type approvals:	ABS, BV, CCS, DNV-GL, KR, LRS, NK, RINA, RRMS

Dimensions

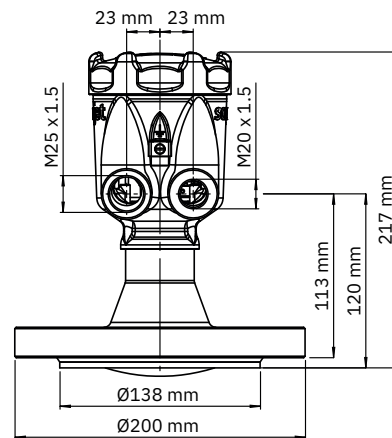
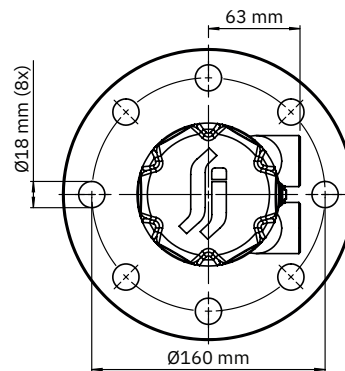
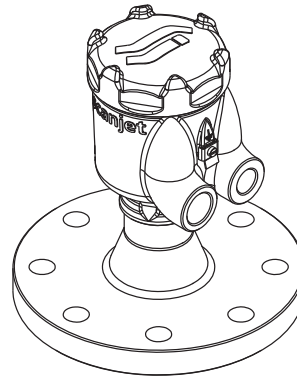

Issue: SCR8_01_2023-11-30

This document and its contents are subject to copyrights and other intellectual property rights owned by Scanjet Marine & Systems AB or any of its affiliates (jointly "Scanjet"). No part of this document may be copied, re-produced or transmitted in any form or by any means, or for any purpose, without Scanjet's prior express written permission. Information and services provided in this document are made as a benefit and service to the user, and no representations or warranties are made about the accuracy or suitability of this information and these services for any purpose.

© Scanjet Marine & Systems AB. All rights are reserved.