

Tank cleaning

SC 45TW

Introduction

The Scanjet SC 45TW is a versatile rotary jet head tank cleaning machine designed for both marine and industrial use. Its robust design ensures that it can be used in the toughest environment in a wide range of applications.

Application

- Marine applications:
It finds purpose in both portable and fixed installations, for vessels such as chemical, product, crude oil, bulk, OBO carriers and FPSO & FSU as well as Offshore.
- Industrial applications:
It is commonly used in the chemical, oil/ petrochemical, pulp/paper industries and as portable tank cleaning machine in applications such as spray dryer (chamber), railcar and truck cleaning, where permanently installed equipment is not an option.

Cleaning is completed significantly faster compared to conventional methods, thereby freeing up more time for production. With Low TCO (Total Cost of Ownership), select the SC 45TW for an ideal solution to keep your cleaning expenses at a minimum.

Working principle

As the cleaning liquid enters the machine, it moves through the turbine and proceeds to the worm gearbox. The turbine's spin powers the high-torque worm gearbox, setting the cleaning machine into a rotational motion. As both the tank cleaning machine's body and nozzle housing turn, powerful water jets are released through dual nozzles, producing a 360° criss-cross cleaning pattern hitting the entire tank surface. The cleaning pattern guarantee thorough cleaning of all surfaces, minimizing the risk of contamination.



Benefits

- Fast cleaning = More time for production
- Low TCO (Total Cost of Ownership)
- Robust design = Quality product with low maintenance
- Powerful Jet = High impact and enables long jet reach
- Used as portable or fixed equipment

Accessories

The SC 45TW comes with a wide range of accessories:

- Custom made hoses for both marine and industrial use
- Hose saddle
- Rubber bumper
- Tools
- Fittings



Performance data

Nozzle size	Supply pressure							
	6 bar (87 psi)		8 bar (116 psi)		10 bar (145 psi)		12 bar (174 psi)	
	Flow ¹ m ³ /h (USgpm)	Jet length m (feet)	Flow ¹ m ³ /h (USgpm)	Jet length m (feet)	Flow ¹ m ³ /h (USgpm)	Jet length m (feet)	Flow ¹ m ³ /h (USgpm)	Jet length m (feet)
2 x Ø 11 mm	22 (97)	15 (49)	25 (110)	17 (56)	28 (123)	19 (62)	31 (136)	20 (66)
2 x Ø 12 mm	25 (110)	15 (49)	29 (128)	17 (56)	32.5 (143)	19 (62)	36 (159)	20 (66)
2 x Ø 14 mm	30 (132)	15 (49)	35 (154)	17 (56)	38.5 (170)	19 (62)	42.5 (187)	20 (66)
2 x Ø 16 mm	34 (150)	14 (46)	38 (167)	16 (53)	42 (185)	18 (59)	45 (198)	20 (66)
2 x Ø 18 mm	35 (154)	13 (43)	40 (176)	15 (49)	45 (198)	17 (56)	49 (216)	19 (62)

¹ Because of variations in part wear, water temperature, installation etc., the flow may differ ±10% from specified value.

Technical data

Inlet working pressure:	3-12 bar (44-174 psi)
Recommended working pressure:	6-10 bar (87-145 psi)
Maximum working pressure:	12 bar (174 psi)
Maximum operating temperature:	95 °C (203 °F)
Maximum ambient temperature:	140 °C (284 °F)

Rotation speed:	2-4 rpm
Material:	Bronze, AISI316L, PEEK, PTFE, Ceramic
Weight:	16 kg (35.3 lb)
Adapter types:	2" BSPP, 2" NPT

Dimensions

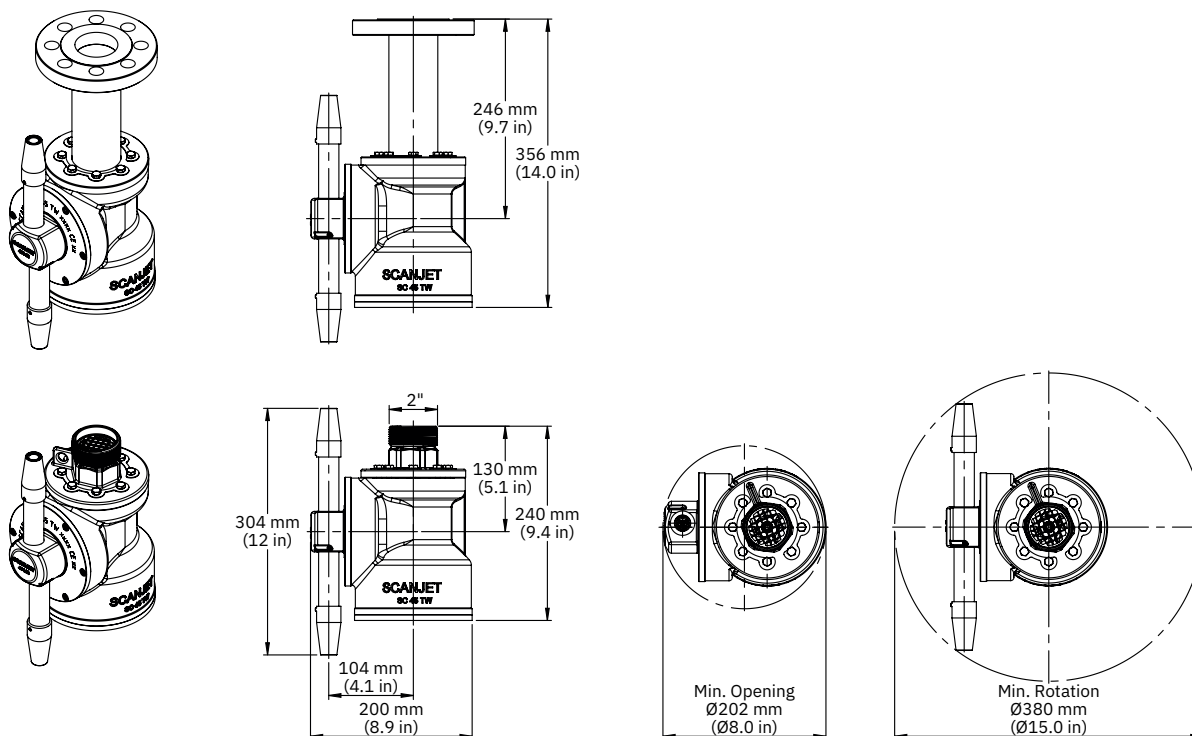

Issue: Scanjet-SC_45TW-datasheet_v20250630

This document and its contents are subject to copyrights and other intellectual property rights owned by Scanjet Marine & Systems AB or any of its affiliates (jointly "Scanjet"). No part of this document may be copied, re-produced or transmitted in any form or by any means, or for any purpose, without Scanjet's prior express written permission. Information and services provided in this document are made as a benefit and service to the user, and no representations or warranties are made about the accuracy or suitability of this information and these services for any purpose.

© Scanjet Marine & Systems AB. All rights are reserved.